

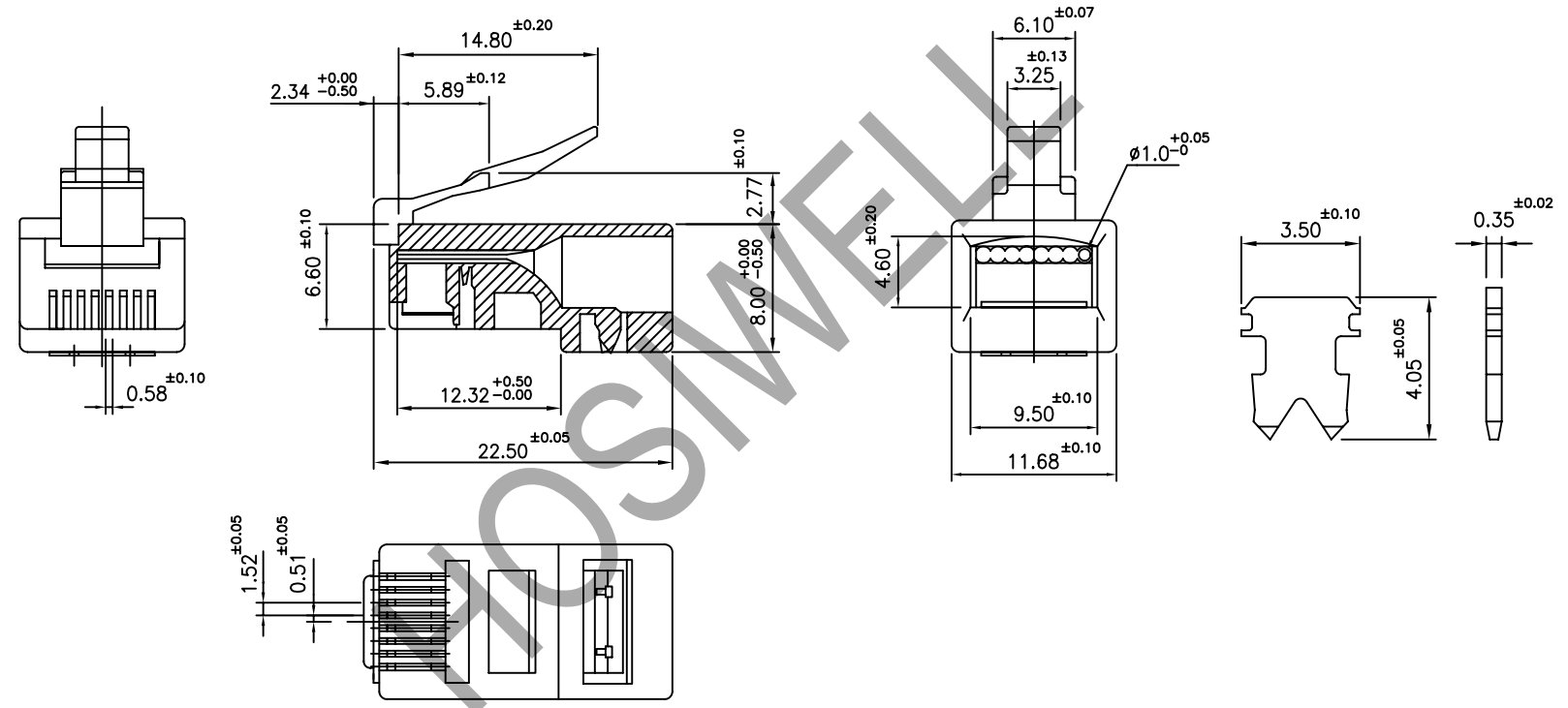

RevNo	Revision note	Date
①		
②		
③		



1. MATERIAL HOUSING--POLYCARBONATE, CLEAR.  
TERMINAL- PHOSPHOR BRONZE, PLATED WITH  
0.381 $\mu\text{m}$  (.000015) MINIMUM THICK GOLD IN  
LOCALIZED GOLD PLATE AREA, GOLD FLASH  
OVER THE REMAINDER, OVER 2.54 $\mu\text{m}$  (.000100)  
MINIMUM THICK NICKEL UNDERPLATE.
2. PLUG WILL ACCEPT 24 TO 28AWG. STRANDED WIRE

①	RJ45 8P8C Cat.5e Plug for UTP Strand Cable	1	PC.
ITEM	DESCRIPTION	Q'TY	UNIT
Designed by	date	Checked by - date	Approved by - date
			Date 24/09/2009
			Size A4
			Scale -
 HOSIWELL TECHNOLOGY CO., LTD.		Part Name	Unit
		RJ45 8P8C Cat.5e Plug	mm.
		Part No.	Issued
		21411	1
Ref. No.	Sheet		
Used On.	1 of 1		