

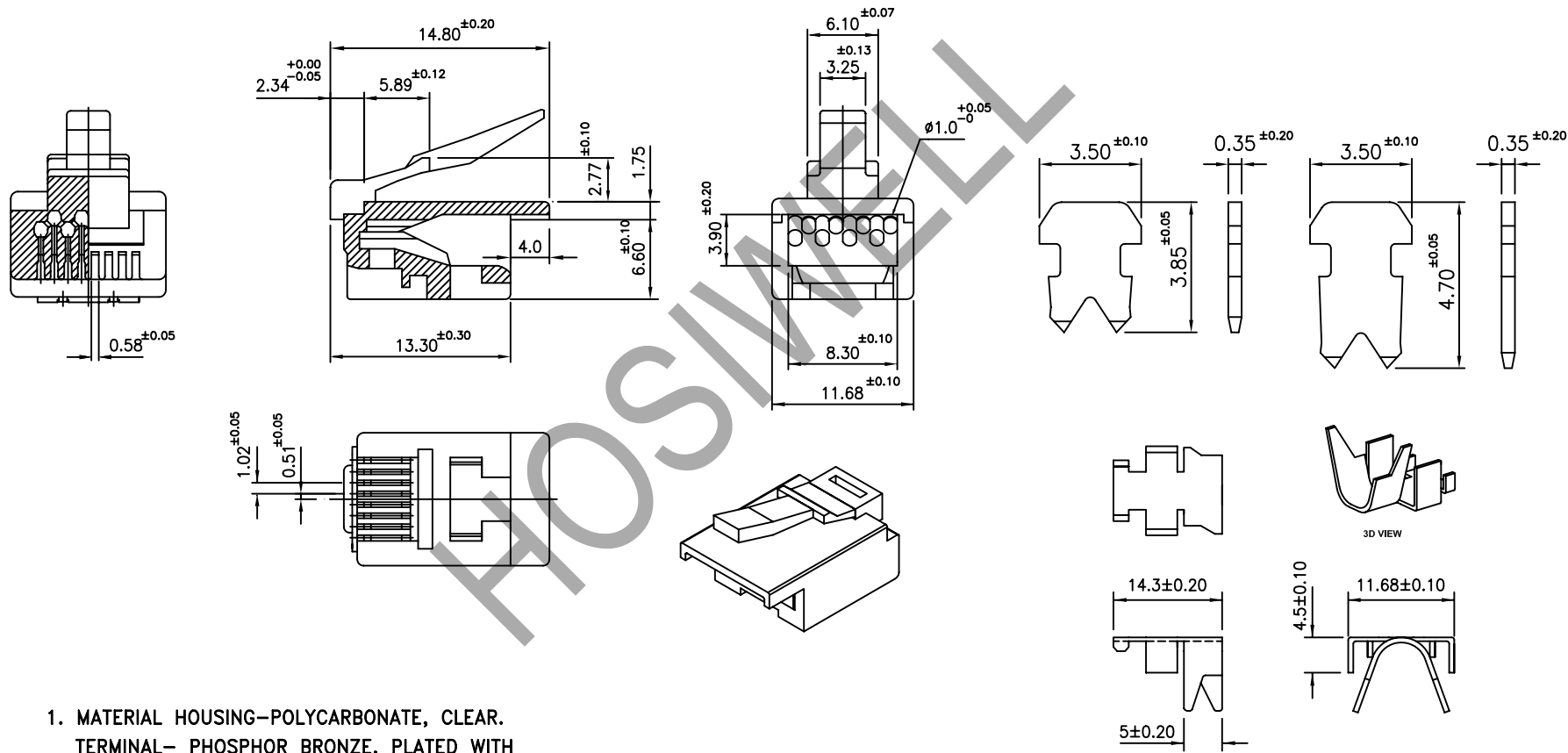

RevNo	Revision note	Date
△		
△		
△		



1. MATERIAL HOUSING-POLYCARBONATE, CLEAR.
TERMINAL- PHOSPHOR BRONZE, PLATED WITH 0.381μm (.000015) MINIMUM THICK GOLD IN LOCALIZED GOLD PLATE AREA, GOLD FLASH OVER THE REMAINDER, OVER 2.54μm (.000100) MINIMUM THICK NICKEL UNDERPLATE.
2. PLUG WILL ACCEPT 24 TO 28AWG. STRANDED WIRE

①	RJ45 8P8C Cat.6 Staggered Plug for UTP Strand Cable	1	PC.
ITEM	DESCRIPTION	Q'TY	UNIT
Designed by	date	Checked by - date	Approved by - date
			Date 24/09/2009
			Size A4
			Scale -
 HOSIWELL TECHNOLOGY CO., LTD.	Part Name	RJ45 8P8C Cat.6 Staggered Plug	Unit mm.
	Part No.	21405	Issued 1
	Ref. No.		Sheet
	Used On.		1 of 1