

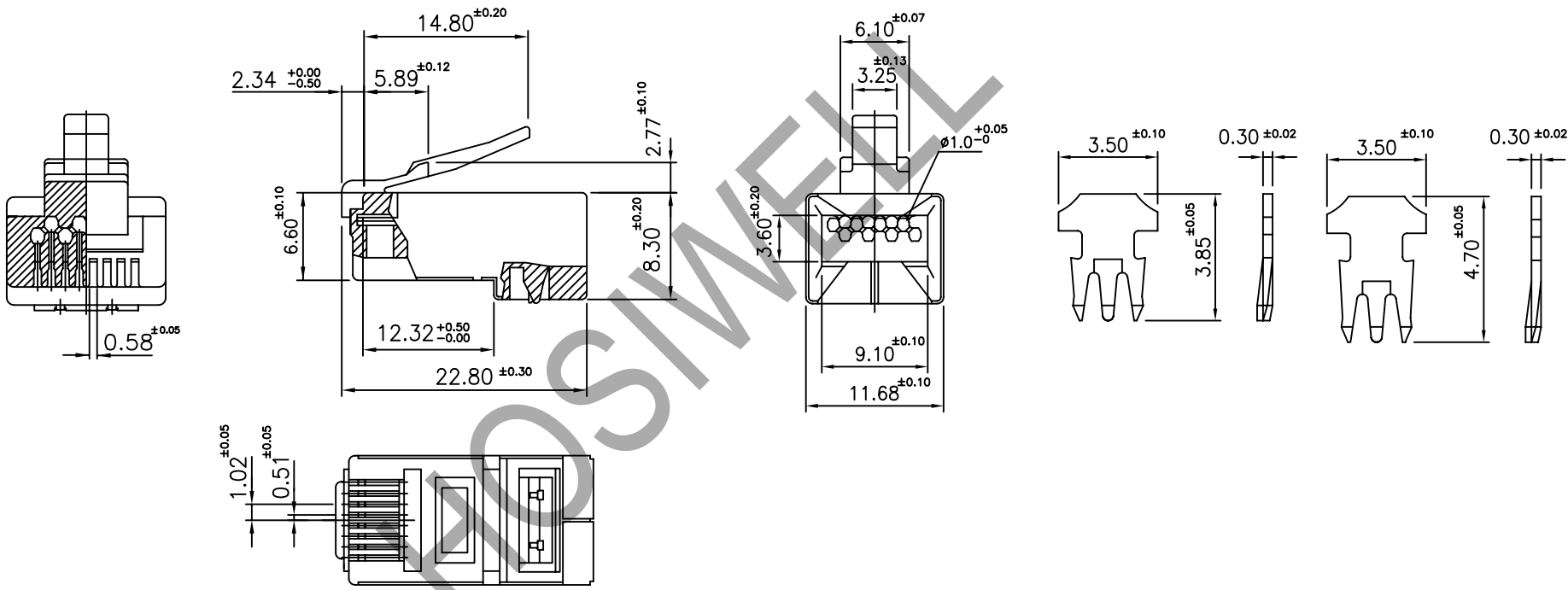

1 2 3 4 5 6 7 8

RevNo	Revision note	Date
①		
②		
③		



- MATERIAL HOUSING-POLYCARBONATE, CLEAR.
 TERMINAL- PHOSPHOR BRONZE, PLATED WITH 0.381μm (.000015) MINIMUM THICK GOLD IN LOCALIZED GOLD PLATE AREA, GOLD FLASH OVER THE REMAINDER, OVER 2.54μm (.000100) MINIMUM THICK NICKEL UNDERPLATE.
 SHIELD- COPPER ALLOY PLATED WITH 2.03μm (.000080) MINIMUM THICK TIN LEAD OVER 2.03μm (.000080) MINIMUM THICK COPPER UNDERPLATE.
- PLUG WILL ACCEPT 24 TO 26AWG. SOLID WIRE

①	RJ45 8P8C Cat.5e Staggered Plug for FTP/SFTP Solid Cable	1	PC.
ITEM	DESCRIPTION	Q'TY	UNIT
Designed by	date	Checked by - date	Approved by - date
			Date 24/09/2009
			Size A4
			Scale -
 HOSIWELL TECHNOLOGY CO., LTD.	Part Name	RJ45 8P8C Cat.5e Staggered Plug	Unit mm.
	Part No.	21404	Issued 1
	Ref. No.		Sheet
	Used On.		1 of 1

1 2 3 4 5 6 7 8