

1 2 3 4 5 6 7 8

RevNo	Revision note	Date
△		
△		
△		

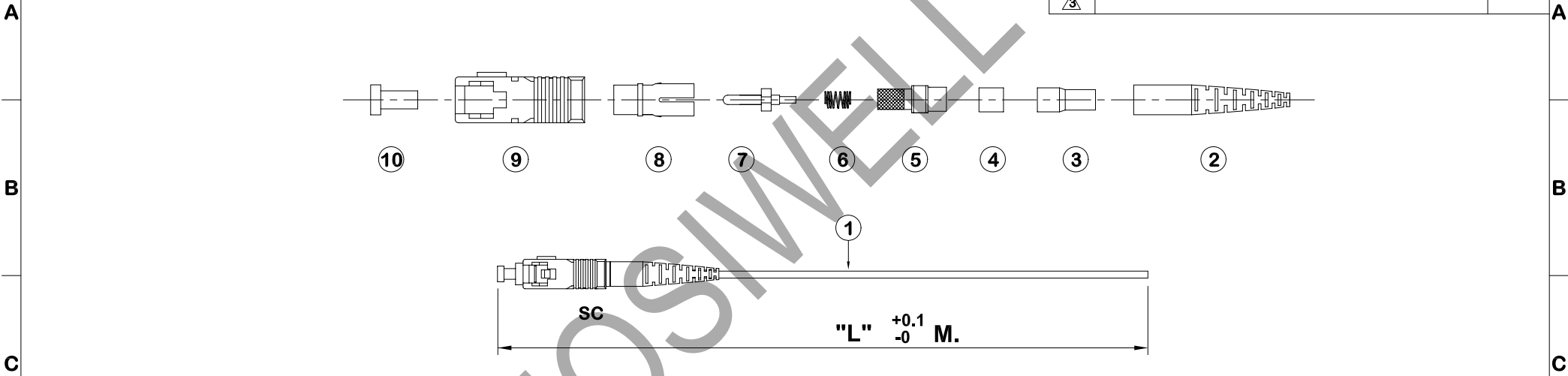

NOTE:

1. Actual Attenuation Supplied on Test Result Sheet per Individually Packed Assembly
2. CABLE INFO :
 - Fiber Type could be Singlemode and Multimode
 - Core/Cladding/Buffering Diameter : 62.5/125, 50/125, 9/125 μ m
 - Flame Resistance : UL-1666 (for riser and general building applications)
3. SC Connector INFO :
 - Ferrule Type: Ceramic

40002-LL-Xn

LL : Fiber Length

Xn : Fiber Type (Example : 06 means OM1 62.5/125 μ m; 05 means OM2 50/125 μ m;

05a means OM3 50/125 μ m aqua color; 09 means OS1 9/125 μ m)

⑩	DUST CAP	1	PC.
⑨	HOUSING	1	PC.
⑧	PLUG FRAME	1	PC.
⑦	FERRULE	1	PC.
⑥	SPRING	1	PC.
⑤	STOP RING	1	PC.
④	RING	1	PC.
③	CRIMP EYELET	1	PC.
②	STRAIN RELIEF BOOT	1	PC.
①	FIBER OPTIC CABLE	1	PC.

ITEM	DESCRIPTION	QTY	UNIT
------	-------------	-----	------

Designed by date	Checked by - date	Approved by - date	Date 29/09/2009	Size A4	Scale -
------------------	-------------------	--------------------	--------------------	------------	------------

 HOSIWELL TECHNOLOGY CO., LTD.	Part Name	Fiber SC Pigtail	Unit	M.
	Part No.	40002-LL-Xn	Issued	1
	Ref. No.		Sheet	
	Used On.		1 of 1	

1 2 3 4 5 6 7 8