

1 2 3 4 5 6 7 8

RevNo	Revision note	Date
▲		
▲		
▲		

A

B

C

D

E

F

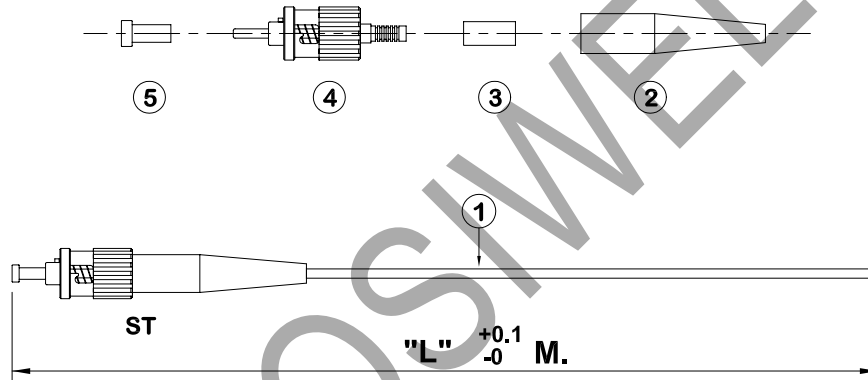

NOTE:

1. Actual Attenuation Supplied on Test Result Sheet per Individually Packed Assembly

2. CABLE INFO :

- Fiber Type could be Singlemode and Multimode
- Core/Cladding/Buffering Diameter : 62.5/125, 50/125, 9/125 μ m
- Flame Resistance : UL-1666 (for riser and general building applications)

3. ST Connector INFO :

- Ferrule Type: Ceramic

40001-LL-Xn

LL : Fiber Length

Xn : Fiber Type (Example : 06 means OM1 62.5/125 μ m; 05 means OM2 50/125 μ m;

05a means OM3 50/125 μ m aqua color; 09 means OS1 9/125 μ m)

⑤	DUST CAP	1	PC.
④	ST CONNECTOR ASSEMBLY	1	PC.
③	CRIMP EYELET	1	PC.
②	STRAIN RELIET BOOT	1	PC.
①	FIBER OPTIC CABLE	1	PC.
ITEM	DESCRIPTION	Q'TY	UNIT

Designed by	date	Checked by	- date	Approved by	- date	Date	29/09/2009	Size	A4	Scale	-
-------------	------	------------	--------	-------------	--------	------	------------	------	----	-------	---



HOSIWELL TECHNOLOGY CO., LTD.

Part Name	Fiber ST Pigtail	Unit	M.
Part No.	40001-LL-Xn	Issued	1
Ref. No.		Sheet	
Used On.		1 of 1	

1 2 3 4 5 6 7 8