

1 2 3 4 5 6 7 8

RevNo	Revision note	Date
△		
△		
△		

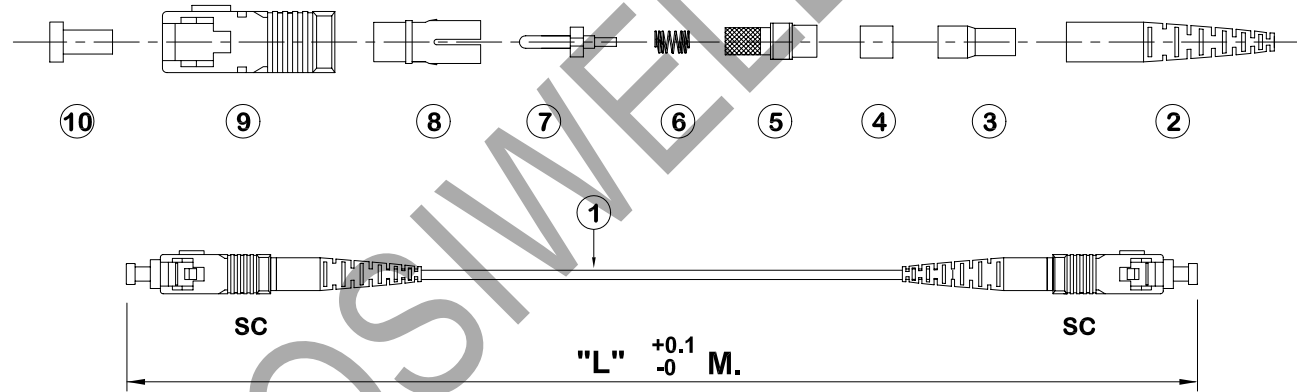

NOTE:

1. Actual Attenuation Supplied on Test Result Sheet per Individually Packed Assembly
2. CABLE INFO :
 - Fiber Type could be Singlemode and Multimode Simplex
 - Core/Cladding/Buffering Diameter : 62.5/125, 50/125, 9/125.µm
 - Flame Resistance : UL-1666 (for riser and general building applications)
3. SC-SC Connector INFO :
 - Ferrule Type: Ceramic

40102-LL-Xn

LL : Fiber Length

Xn : Fiber Type (Example : 06 means OM1 62.5/125 µm; 05 means OM2 50/125 µm;

05a means OM3 50/125 µm aqua color; 09 means OS1 9/125 µm)

⑩	DUST CAP	2	PCS.
⑨	HOUSING	2	PCS.
⑧	PLUG FRAME	2	PCS.
⑦	FERRULE	2	PCS.
⑥	SPRING	2	PCS.
⑤	STOP RING	2	PCS.
④	RING	2	PCS.
③	CRIMP EYELET	2	PCS.
②	STRAIN RELIEF BOOT	2	PCS.
①	FIBER OPTIC CABLE	1	PC.

ITEM	DESCRIPTION	Q'TY	UNIT
------	-------------	------	------

Designed by date	Checked by - date	Approved by - date	Date	Size	Scale
			29/09/2009	A4	-

 HOSIWELL TECHNOLOGY CO., LTD.	Part Name	Fiber Patch Cord SC-SC Simplex	Unit
	Part No.	40102-LL-Xn	Issued
	Ref. No.		Sheet
	Used On.		1 of 1

1 2 3 4 5 6 7 8